

# Ellips<sup>®</sup> 1700

## Cryogenic On-Off Valve with s.s. bellow Pneumatic actuator

High quality s.s. valve for gases and cryogenic fluids. Bevel seat valve with STÖHR bellow sealing for long life and tightness. Body made from solid stainless steel. Butt welded end connections or according to customer specification.

**The ELLIPS valve is characterised by a very good DN/cv-value ratio. Therefore the ELLIPS valve allows to apply smaller sizes than usual.**

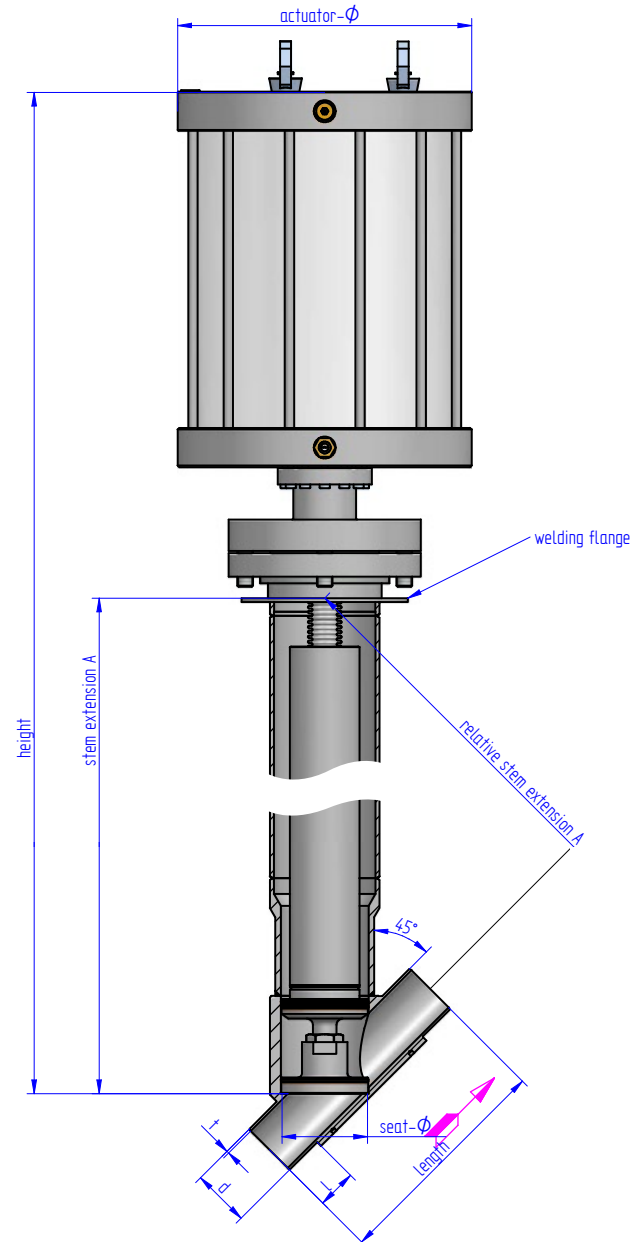

DN	PN	Connection	Cv	Drawing No.
8	25	10,0 x 1,0 x 25	3	18-1700.12.1
10	25	12,0 x 1,0 x 25	5	18-1700.12.2
15	25	18,0 x 1,5 x 25	12	18-1701.12.1
20	25	23,0 x 1,5 x 25	21	18-1702.12.1
25	25	28,0 x 1,5 x 30	33	18-1703.12.1
32	25	35,0 x 1,5 x 30	54	18-1704.12.1
40	25	41,0 x 1,5 x 35	84	18-1705.12.1
50	25	53,0 x 1,5 x 50	132	18-1706.12.1
65	25	70,0 x 2,0 x 50	223	18-1707.12.2
80	25	85,0 x 2,0 x 50	338	18-1708.12.1
100	25	104,0 x 2,0 x 50	528	18-1709.12.1

All length [mm], cv-value [m<sup>3</sup>/h]

Technical data	Technical Design
Service fluids	N <sub>2</sub> , O <sub>2</sub> , Ar, H <sub>2</sub> , He, N <sub>2</sub> O, CO <sub>2</sub> , natural gas**
Operating temperature fluid	-196°C (-253°C) to +50°C
Operating temperature environment	-30°C to +50°C
Body material	Stainless steel
Body type	Bevel seat (with free flow)
Seat sealing	Metal/PCTFE, He-leak rate seat 1 x 10 <sup>-6</sup> mbar l/s Metal/PTFE, He-leak rate seat 1 x 10 <sup>-6</sup> mbar l/s Metal/Metal, He-leak rate seat 1 x 10 <sup>-3</sup> mbar l/s
Body sealing	Metal sealing, He-leak rate to outside 1 x 10 <sup>-8</sup> mbar l/s
Stem sealing	s. s. bellow, physically tight
Surface of components	Machined, grinded, electropolished or passivated
Installation position	Actuator on top, ca. 10° from vertical, horizontal or vertical flow
Material certificates	DIN EN 10204/3.1B AD2000-A4

\*\* All dangerous, toxic or corrosive fluids with an appropriate material selection